

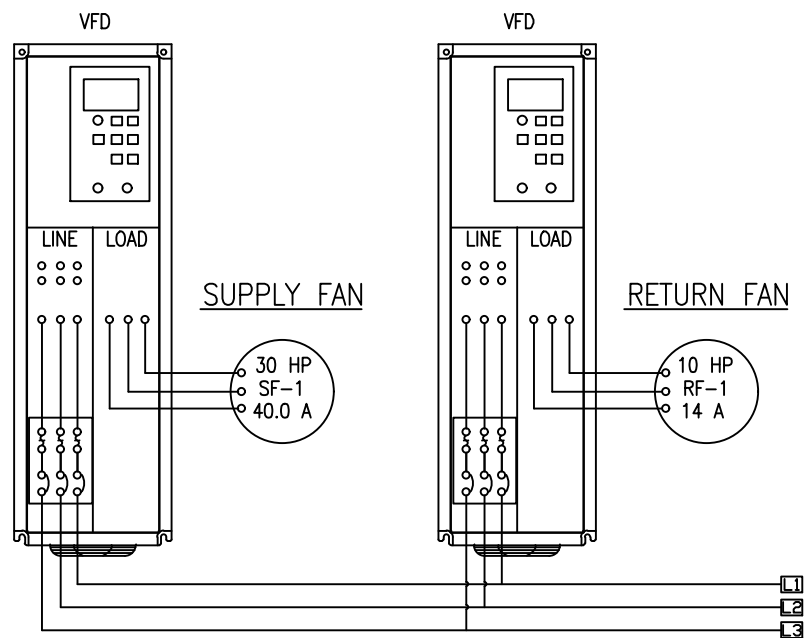

| REV | DESCRIPTION | DATE | BY |
|-----|-----------------|------|----|
| A | INITIAL RELEASE | | |

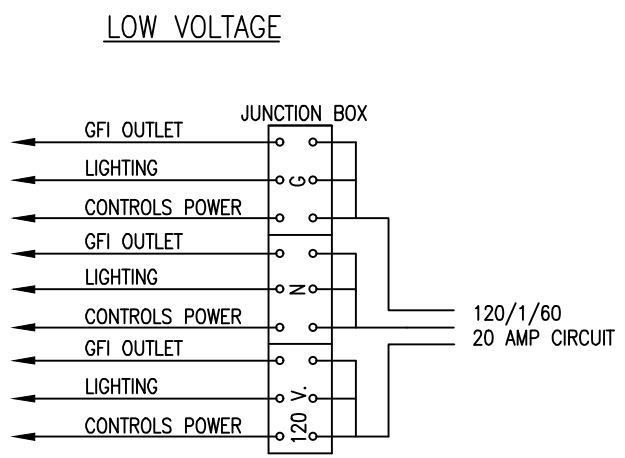

460 V
 SINGLE POINT CONNECTION
 LINE IN
 FLA: 54.0 A
 MCA: 64.0 A
 MOCP: 80.00 A

HIGH VOLTAGE
 MAIN FUSE DISCONNECT PROVIDED BY OTHER



| ITEM | PART NO. | DESCRIPTION | QTY |
|--|----------|---|-----|
| <p>UNLESS OTHERWISE SPECIFIED DIMENSIONS ARE IN INCHES</p> <p>UNSPECIFIED TOLERANCES</p> <p>DECIMALS: in mm .X ± .1 ± 2.5 .XX ± .06 ± 1.52 .XXX ± .031 ± 0.787 ANGULAR: ± .5°</p> | | | |
| <p>UNITECH  2700 South 900 West Salt Lake City, Utah 84119-2418</p> | | <p>SAMPLE PROJECT ELECTRICAL DIAGRAM RTU</p> | |
| <p>DRAWN BY: RJV CHECKED BY: [blank]</p> | | <p>DATE: 8/7/13 SCALE: N.T.S. DRAWING NO.: ED-RTU REV: A</p> | |

THIS DRAWING, AND THE INFORMATION SHOWN HEREON, IS THE SOLE PRODUCT OF UNITECH, LLC. NO REPRODUCTION IS AUTHORIZED WITHOUT THE EXPRESS WRITTEN PERMISSION FROM UNITECH, LLC. - PATENTS PENDING